

Work supports - Hydraulic advance

Shown: WFM-72, WFL-112



WF series

Enerpac work supports provide either additional non-fixed location points to the clamps, or support to larger or thin section workpiece components, always in order to minimize workpiece deflection during machining.

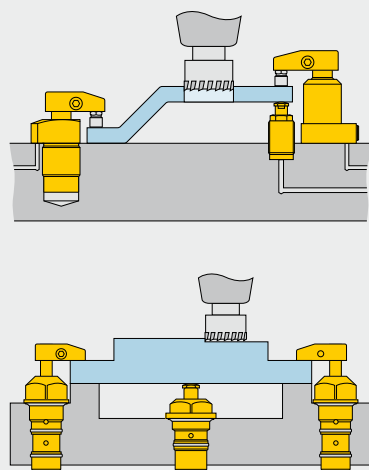

In order to load the workpiece sideways over the work supports, hydraulic advanced models are being used.



For unobstructed part loading

- Plunger stays retracted until pressure is applied allowing unobstructed loading
- Low pressure lock-up capability enables the use of machine tool hydraulic systems
- High rated support capacities allow for more compact fixture design
- Corrosion resistant materials – compatible with most coolants and environments
- Threaded and manifold air vent ports allow fixturing that prevents coolants and debris from being ingested into the mechanism
- Minimized deflection increases machining accuracy
- Multiple mounting configurations for design flexibility
- Contact bolt included

Four mounting styles

WFM series, Manifold models

Eliminates the need for fittings and tubing on the fixture.

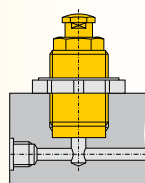

WFT series, Threaded models

Offers the flexibility of side or bottom porting.

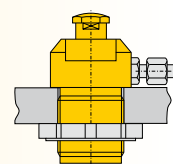

WFL series, Lower flange models

Plumbed directly – no fixture hole required.

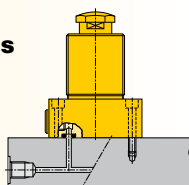

WFC series, Cartridge models

Can be designed into narrow fixture plates as thru-hole mounting is fully functional.

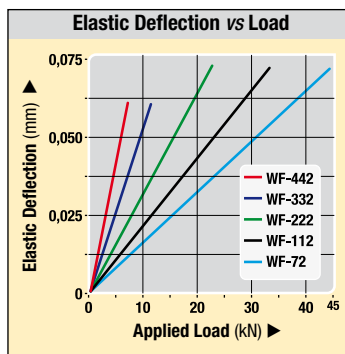
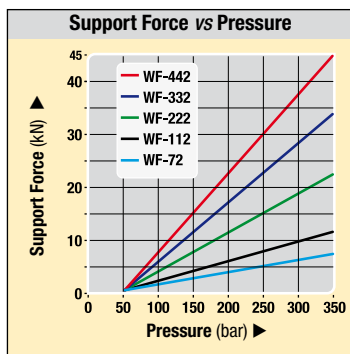
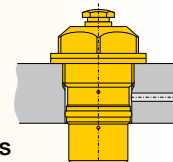

Deflection chart:

Elastic deformation of the work support resulting from the application of load.

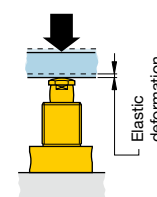

Product selection

Max. support force	Support plunger stroke	Manifold mount	Threaded body	Lower flange	Cartridge style	Operating pressure		Plunger contact spring force		Oil capacity	Max. oil flow
						min. bar	max. bar	ext. N	retr. N		
7,3	9,9		-	-	-	48	350	8,9	25,8	0,66	0,7
7,3	10,2	-		-	-	48	350	8,9	25,8	0,66	0,7
11,1	10,2	-	-		-	48	350	15,1	23,1	0,98	1,0
22,2	10,4	-	-		-	48	350	9,3	86,8	3,11	3,1
33,4	13,5	-	-		-	48	350	17,8	77,9	3,93	3,9
44,5	16,5	-	-		-	48	350	14,7	97,9	4,92	4,9
7,3	9,9	-	-	-		48	350	8,9	25,8	0,66	0,7
11,1	9,1	-	-	-		48	350	15,1	23,1	0,98	1,0
22,2	10,4	-	-	-		48	350	9,3	86,8	3,11	3,1

* This product is made to order. Please contact Enerpac for delivery information before specifying in your design.

WFM series

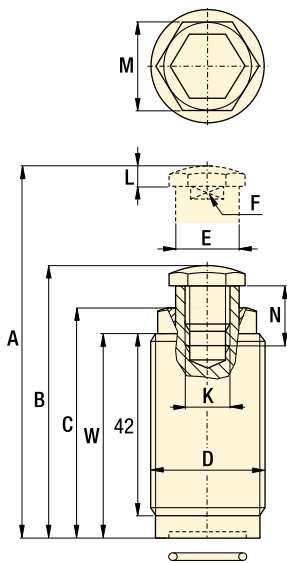

WFT series

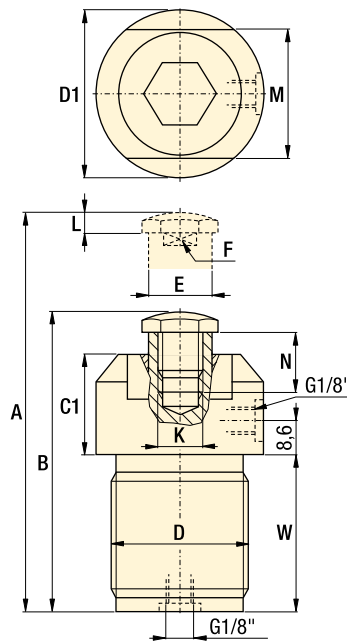

WFL series

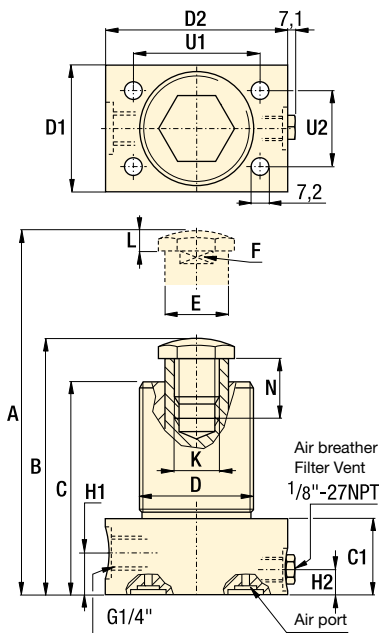

WFC series

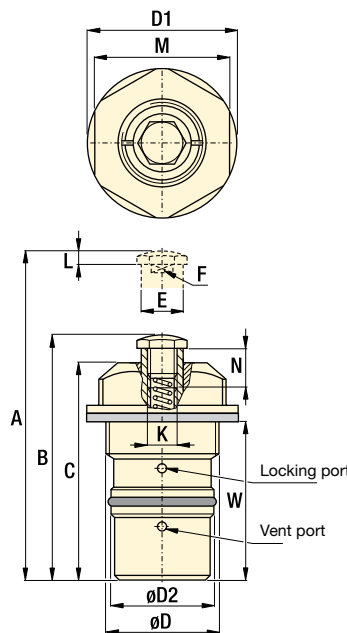

Force: 7,3 - 44,5 kN

Stroke: 9,1 - 16,5 mm

Pressure: 50 - 350 bar

- E** Cilindros de soporte
- F** Vérin anti-vibreur
- D** Abstützylinder

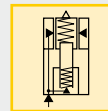

Options

Accessories

86 ▶



In-line filters

193 ▶



Important

WARNING!

Support force and clamping force must be matched. Support force should be at least 150% of clamping force.

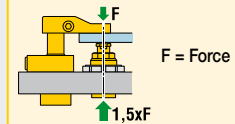

Do not exceed maximum flow rates to avoid premature lockup.

Custom cylinders including longer stroke lengths are available on request.

Mounting dimensions ▶50 ▶

Product dimensions in mm [± 0.1]

Model number	Capacity kN	A	B	C	C1	D	D1	D2	E	F	H1	H2	K	L	M	N**	U1	U2	W	kg
WFM-72	7,3	76,7	66,8	55,9	-	M30x1,5	-	-	15,01	13,0	-	-	M10x1,5	4,6	24,1	13,0	-	-	50,8	0,2
WFT-72	7,3	89,7	79,5	-	26,2	M35x1,5	43,7	-	15,01	13,0	-	-	M10x1,5	4,6	34,0	13,0	-	-	41,9	0,2
WFL-112	11,1	99,8	89,9	78,7	27,4	M35x1,5	38,1	ø60,4	15,98	12,4	14,2	17,8	M10x1,5	4,6	-	18,5	41,1	23,9	-	0,6
WFL-222	22,2	104,9	94,5	78,0	26,4	M68x1,5	69,9	82,6	38,00	25,4	14,0	13,2	M20x2,5	6,1	-	23,4	55,6	55,6	-	2,2
WFL-332	33,4	112,3	98,8	87,9	27,2	ø 73,2	76,2	88,9	44,98	30,0	13,5	10,9	M20x2,5	6,1	-	23,6	62,0	62,0	-	2,9
WFL-442*	44,5	129,3	112,8	103,1	30,2	ø 85,9	88,9	101,6	54,99	36,6	13,5	10,9	M20x2,5	6,1	-	31,5	74,7	74,7	-	4,3
WFC-72	7,3	81,8	71,9	62,5	-	M33x1,5	42,2	30,0	15,01	13,0	-	-	M10x1,5	4,6	38,1	13,0	-	-	50,3	0,4
WFC-112	11,1	102,4	93,2	82,0	-	M42x1,5	57,2	38,1	15,98	12,4	-	-	M10x1,5	4,6	50,8	18,5	-	-	60,2	0,9
WFC-222	22,2	115,8	105,4	91,4	-	M60x1,5	76,2	57,2	38,00	25,4	-	-	M20x2,5	6,1	69,9	23,4	-	-	69,0	1,8

* This product is made to order. Please contact Enerpac for delivery information before specifying in your design.

** Note: Dimension N is factory set. May change on types 222, 332 and 442 due to adjusted contact spring force.

Note: For manifold mounting dimensions (▶50).

www.enerpacwh.com